

# The Spectrum

© Center for Photochemical Sciences

Volume 20  
Issue 1 2007

A night sky filled with stars and a bright comet streaking across the frame. The comet's tail is a long, glowing blue and white line that tapers towards the right. The stars are scattered throughout the dark background, with some appearing as small, bright points of light. The overall scene is a dramatic representation of the night sky.

**The Past as Prologue**  
An Interview with James N. Pitts, Jr.

# a quarterly publication

Center for Photochemical Sciences  
Bowling Green State University  
Bowling Green, Ohio 43403-0210  
419.372.2033

#### Faculty

**Executive Director**  
D. C. Neckers

#### Biological Sciences

George S. Bullerjahn  
Zhaohui Xu

#### Chemistry

Pavel Anzenbacher  
John R. Cable  
Felix N. Castellano  
Ksenija Glusac  
Thomas H. Kinstle  
H. Peter Lu  
Michael Y. Ogawa  
Massimo Olivucci  
Michael A. J. Rodgers  
Deanne L. Snavely  
Alexander N. Tarnovsky  
R. Marshall Wilson

#### Physics and Astronomy

Bruno Ullrich

#### Scientific Advisory Board

Eugene G. Arthurs  
Robert E. Blankenship  
Miguel A. Garcia-Garibay  
Harry B. Gray  
Rong-Chang Liang  
Josef Michl  
George R. Newkome  
Norman Nitschke  
Kenneth G. Spears  
Timothy M. Swager  
John L. West  
David G. Whitten

#### *The Spectrum*

Editor Pat Green  
Contributing Editor Michael Woods  
Production Editor Alita Frater

*The Spectrum* (ISSN 1044-5536)  
is published four times yearly at no  
charge. For subscriptions e-mail  
photochemical@listproc.bgsu.edu

*The Spectrum* is available on the web at  
[www.bgsu.edu/departments/photochem](http://www.bgsu.edu/departments/photochem)

*The Spectrum* is published by the  
Center for Photochemical Sciences  
at Bowling Green State University,  
Bowling Green, Ohio. The mission  
of *The Spectrum* is to disseminate  
the latest research and news in the  
photochemical sciences to a general  
audience worldwide.

# The Spectrum

## special feature perspective on

4 the past as prologue  
an interview with **James N. Pitts, Jr.**

## viewpoint

3 **Douglas C. Neckers**

#### On the cover

Photograph of light from xenon light source across University of California-Riverside campus to a detector for differential optical absorption measurements (DOAS) using a 1 km pathlength (Platt, U.; Perner, D.; Winer, A. M.; Harris, G. W.; Pitts, Jr., J. N. *Geophys. Res. Lett.* **1980**, 7, 89-92).



Sometimes one encounters an article important enough to warrant extra space. When Mike Woods' interview with Jim Pitts landed in my in box, I decided that it was significant enough to literally clear the decks. We are devoting the entire issue of *The Spectrum* to Jim's wonderful story. It seems a fitting way to begin the 20<sup>th</sup> year anniversary of *The Spectrum* as well.

Pitts' career mirrors that of many young scientists of the early World War II generation. Rather than being drafted into the armed forces, he was sent to work in a defense department laboratory. Pitts was just twenty-one when commandeered. In his case, Jim worked in the chemical warfare service under the immediate direction of Francis Blacet and the ultimate direction of W. Albert Noyes, Jr. Noyes was identified by Harvard President (and organic chemist) James Bryant Conant to lead this multitasked service. The outcome of the effort and the names of the 400 plus participants were recorded in a book edited by Noyes, Jr., entitled *Chemistry: A History of the Chemistry Components of the National Defense Research Committee, 1940-1946*.

Many of our readers around the world may know of other individuals in their late 80s/early 90s who served similarly in England, France, Germany, the Soviet Union, Japan and other countries. Out of this work came the atomic bomb and its terrible successors. Out of this work also came some of the most heinous chemicals known to man—the nerve gasses, SARIN, SOMAN AND TOBUN. Not a month goes by that one of the nations of the world doesn't let on that (1) they have huge stores of these weapons, (2) the stores are so massive that destroying them will not be done any time soon, and (3) the canisters in which they are contained are rusting, decaying and in other ways making continued storage unsafe. In the United States, we know that tons of these various compounds were made and stored between 1946 and 1952. Our big oil companies made them presumably with a sizeable profit margin. Less is known about synthesis and storage in the other combatant nations of World War II. The issue is pertinent still today in that destruction of stores, and the potential for capture or purchase of stocks by terrorists, is always with us.

In another part of my life, I work with the Robert H. Jackson Center in Jamestown, New York, to preserve the legacy of a Supreme Court Justice who was also the chief U.S. prosecutor at the Nürnberg military tribunal following World War II. The Jackson Center has made a strong effort to capture oral histories of the recollections of those still living who knew Jackson and worked with him.

Jim Pitts' story leads me to make an appeal to *The Spectrum's* audience. I'm asking readers to let me know about scientists, or those who worked with scientists, who might still be living from the World War II era, from whom we can gather information about the transfer of the lethal non-nuclear technical achievements of World War II. I propose to gather the information as oral histories so that a record can be maintained for future scholars and students.

If such individuals are known, please let me know at [neckers@photo.bgsu.edu](mailto:neckers@photo.bgsu.edu). Thank you.

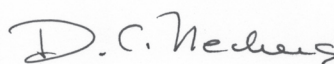

an interview with James N. Pitts, Jr.

The Haagen-Smit Award given to James N. Pitts, Jr., in 2002 for in recognition of his substantial and unique contributions to the fields of air pollution and atmospheric chemistry stated, "Dr. Pitts is often found at the forefront of emerging air quality issues and has tirelessly worked for good science and protection of public health and welfare." He is the recipient of numerous other awards and received in May 2007 the Carl Moyer Award from the Coalition for Clean Air for Scientific Leadership and Technical Excellence.



Courtesy of Sergey Nizkorodov

The genealogy of most modern photochemical scientists includes legendary figures who tower over this field like titans. W. A. Noyes, Jr., for instance, occupies one giant square in that scientific family. Francis E. Blacet, who pioneered gas phase photochemistry, claims another. Philip A. Leighton similarly was an academic father or grandfather, working with Blacet to develop the apparatus for microanalysis of gases that preceded mass spectrometry and gas chromatography.

Every photochemical scientist recognizes those names. Many have read research papers and textbooks that these pioneers contributed. James N. Pitts, Jr., is among precious few who count individuals like Noyes, Blacet, and Leighton as not just mentors and scientific role models, but as personal friends.

Pitts himself has the trappings of legend, thanks to a remarkable career in atmospheric photochemistry. His research from the late 1960s through the 1980s established much of the scientific basis for efforts to understand the chemistry of the troposphere, the lower atmosphere, and its role in producing air pollution.

Look at the science underpinning California's worldwide leadership in the development and implementation of scientifically sound and technologically effective air pollution control strategies and regulations. Chances are you will find research done by Jim Pitts and colleagues. Pitts began with studies on singlet-oxygen chemistry, and transitioned into research on the presence and formation of mutagens in aerosols found in photochemical smog.

As a founding Director of California's Statewide Air Pollution Research Center, located at UC Riverside, Pitts attracted a group of brilliant graduate students, postdoctoral fellows and other young chemists. Jim's collaborators and scientific progeny include Roger Atkinson, Janet Arey, Arthur Winer, Alan Lloyd, Hajime Akimoto, Ernesto Tuazon, Jeff Gaffney, and one Barbara J. Finlayson, who would become Jim's spouse. That group established much of the basic chemistry

and kinetics of the gas-phase reactions involved in air pollution and developed methods for studying and detecting these species.

They built the first smog chamber, and did landmark studies on the fundamental processes and production rates of ozone and other oxidants. Pitts' publications include more than 370 research papers. He co-authored four books (including the recent *Chemistry of the Upper and Lower Atmosphere*), written with Finlayson-Pitts, that are standard references in atmospheric chemistry and are used worldwide in training future air quality scientists.

In this interview with *The Spectrum*, Pitts ventures beyond his well-known published research to provide fascinating glimpses into the personalities and projects that dominated photochemistry as the science was emerging. Some of the most compelling episodes involve the roles that Pitts, Blacet, and others played as scientists and were enlisted in classified research that helped win World War II.

For instance, Pitts recalls how, one-by-one, certain scientists and graduate students mysteriously disappeared from UCLA and other college campuses in the early 1940s to serve on secret research teams. Pitts was among those who wound up on unlikely missions, finding himself at one point "tending" a flock of goats from Puerto Rico that "also" wore gas masks in clouds of CW agents.

James N. Pitts, Jr., is Professor of Chemistry Emeritus at UC Riverside and currently a Research Chemist in the Department of Chemistry at UC Irvine. Jim's CV details an impressive life in science.

***The Spectrum:* When did you become interested in science as a child and what factors fostered that interest?**

**Pitts:** Before I address these questions, let me state at the outset that from my perspective over some 60 years, there have been three photochemists who had a major influence/impact both scientifically and personally on me: Francis E. Blacet; Philip A. Leighton, my academic father and grandfather; and W. A. Noyes, Jr. Starting in the 1930s, these three were true pioneers in the emerging field of photochemistry as we know it today.

Furthermore, they made significant contributions to our country in their laboratory and field studies in chemical warfare in WWII. Following the war they were responsible for starting the Informal Conference on Photochemistry in the early 1950s, an event that grew in size and international impact over the decades. They have been my personal friends and scientific role models in peace and war. I'd like to dedicate this interview to them.

**The Spectrum: Done. And so, tell us about how you got interested in science.**

**Pitts:** I always had some interest in math and science as a kid, but the outdoors was my true love, for example, body surfing at the local beaches, and fly fishing for trout while camping in the High Sierras with my mother and dad and buddies in the late 1920s to late 1930s. I could really “dig” nature and the charms of our environment before the mass migration of humans into our pristine areas of Southern California at the onset of World War II.

I was really turned on to chemistry by my 11<sup>th</sup> grade high school chemistry teacher, Miss Isabelle Wilson. She was a grey haired lady with a cane, and had been a student of G. N. Lewis at UC Berkeley in the 1920s. Her love of, and dedication to, the subject were inspirational and long lasting. Indeed they led to my entering UCLA in January of 1939 as a major in pre-chemical engineering—with the intent of then transferring to UC Berkeley for my junior and senior years—because UCLA did not have an engineering school at that time.

However, subsequent events, including great teachers, grading “pop quizzes” in Chemistry IB after I had just taken the course, and as an undergraduate the possibility of carrying out real research with a faculty member, led to one of the best decisions of my life. To heck with engineering and Berkeley... I'm going to stay and get my Bachelor's Degree in Chemistry at UCLA!

**The Spectrum: How did you find your way to UCLA and especially to Francis E. Blacet?**

**Pitts:** I grew up in the West Side of LA near the Baldwin Hills where the 1932 Olympic teams had their “quarters”. The actual events were held next to the USC campus in the new Coliseum, which was built specifically for this huge event. Initially, I commuted by street car to Manual Arts High School (and Miss Wilson) and then in 1939 drove to UCLA in my “cool” black and yellow 1932 Model B Ford coupe. It had a rumble seat which my buddies in chemistry,

including George Pimental, liked to occupy during double dates, for example, to the pre-war Palladium in Hollywood... which featured the world's best swing bands, for example, Benny Goodman, Artie Shaw, Tommy Dorsey, and so forth. I had to drive, damn it!!!

**The Spectrum: Why UCLA?**

**Pitts:** I chose UCLA, in part, because it was a family tradition. My mother went there in the early 1920s when it was a “Teacher's College” located in downtown L.A. Additionally, my cousin, Florence Anderson, was in the first class, 1928, to occupy the new campus in Westwood and in the first graduating class, 1932, with a major in mathematics.

Today Florence is in a rest home adjacent to our UC Irvine campus. She has some remarkable and to the current generation “shocker stories” of a “mere woman”, even with a B.A. degree, getting a job in industry, in areas of science, engineering, and so forth in the 1930s. The only openings for a woman were secretarial. She later took an M.S. degree in math and during WWII taught inertial navigation techniques to pilots in the Navy!!! Good show!

Other significant reasons for choosing UCLA were that *there were no tuition charges* and it already had an excellent reputation in chemistry. As an entering freshman, I took Chemistry IA in the spring of 1939 from James McCullough. He was an excellent teacher and nice guy. Then in the fall quarter of 1939 I took Chemistry IB, inorganic qualitative analysis, from Francis E. Blacet. At his kind invitation, as a sophomore, I graded “pop quizzes” in chemistry IB for “FEB”. Subsequently, I served as an undergraduate lab assistant for him in that course.

**The Spectrum: In those days, were teaching/lab assistants paid?**

**Pitts:** My starting salary as a grader in Chem IB was 40 cents per hour! From today's perspective this may seem outrageously low, but that was indeed a “different era”. For example, in my freshman year at UCLA I spent a significant amount of my free time at Ralph's grocery store in Westwood Village (which was immediately adjacent to the campus). My job was primarily to stand at the checkout counter and pack and carry out groceries for nice “little old ladies” who had a big load. You see, in those archaic days there were no such things as today's grocery carts *on wheels*. Everything was carried by hand.

Tips were rare, around 10 to 25 cents (WOW!) and generally came from these “nice little old ladies”, who were



not that well off. Rarely did they come from the wealthy ladies with big expensive cars and chauffeurs, who lived in the many elegant mansions in the hills around the campus. This gave me some early understanding of what the “real world” was like outside of the “Hallowed” university walls. Furthermore, you can see why 40 cents an hour as an undergraduate reader or lab assistant was a really good deal!!!

**The Spectrum:** Blacet had quite some influence on you?

**Pitts:** In response to your question about “Blacet’s influence”, during his lifetime, and still today, scientific input and personal advice from “The Chief”, our nickname for Blacet, (translated to “El Jefe” in WWII when he led our chemical warfare team) given with grace, charm and understanding, has been, and continues to be, a key element of my scientific and personal lives.

**The Spectrum:** And back on campus Jim Pitts meets spectroscopy...

**Pitts:** In my junior year as an undergraduate research assistant for Dr. McCullough, I took absorption spectra of a series of aromatic selenium compounds. The instrument was a brand new UV-visible spectrophotometer, manually operated with four sample cells and a “blank” reference cell, just invented, developed, and introduced for sale by the new Beckman Instrument Company. Arnold Beckman was a really sharp guy (and very nice too), as evidenced by his successes in so many areas in the following decades. Those spectra I took were beautiful! I was “hooked” for life on spectroscopy, and its multitude of applications, to both fundamental and applied research areas of major importance to science and society then and now!

**The Spectrum:** Were you interested in air pollution and atmospheric chemistry at that point, or did it result from Blacet’s influence?

**Pitts:** Actually in the 1930s and 1940s there was little academic interest in the U.S. of a new kind of air pollution, “L.A. Smog”. The London type, smoke plus fog plus chilly temperatures had been known and commented on for centuries. The “new” one occurred in the Los Angeles Air Basin on bright sunny days with on-shore breezes. And as we later learned, caused, not only severe eye irritation and very poor visibility, but other serious health and environmental impacts.

This newly recognized atmospheric phenomenon actually had been observed centuries ago. The topography and meteorology of southern California were “made for it”! Thus, for example, on his landing at Los Angeles Harbor on October 8, 1542, Spanish explorer Juan Rodriguez Cabrillo wrote: “Mountain peaks were visible in the distance, but their bases were obscured. Smoke from Indian campfires rose vertically for only a few hundred feet and spread like a pall over the entire area.” Cabrillo named the site “La Bahia de los Fumos”, or the Bay of Smokes.

**The Spectrum:** And Blacet did early work on ozone formation.

**Pitts:** Francis Blacet had a major influence on my entire career, not only in fundamental photochemistry, but also in its application to major areas of atmospheric chemistry and air pollution. For example, in 1952 he published an article suggesting that the photolysis of NO<sub>2</sub> in air forms O<sub>3</sub>.

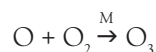

Blacet said, “However, the postulated steps are reasonable and indicate a way in which nitrogen dioxide may serve as an intermediate in making solar radiation available for use in the synthesis of ozone from atmospheric oxygen.” (*Ind. Eng. Chem.* **1952**, *44*, 1339)

This reaction still remains the sole known source of anthropogenically produced ozone. Subsequently, NO reacts rapidly with ozone reforming NO<sub>2</sub>.

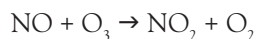

Indeed, utilization of a wide range of photochemical and spectroscopic techniques has been essential to my research interests over some six decades—fundamental processes in photochemistry and photooxidations and their roles in the atmospheric chemistry of our natural and polluted troposphere. Major fields have included photochemical air pollution, for example, ozone, NO<sub>2</sub> and other oxides of nitrogen and the ambient levels and formation and fates in real and laboratory atmospheres containing hazardous air pollutants (HAPs). These include certain pesticides widely used in and around our homes and agricultural fields, and gaseous and particulate mutagens and carcinogens.

Specific areas include spectroscopic, kinetic, product, and mechanistic studies of the interactions of environmentally

and health relevant natural and anthropogenic compounds, such as “Pandora’s  $\text{NO}_x$ ” which in the vapor phase includes



and

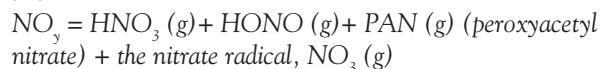

Reactive oxygenated species in the vapor phase include ozone, OH and  $\text{RO}_2$  radicals, oxygen atoms and singlet molecular oxygen  $\text{O}_2(^1\Delta)$ .

Over the decades my colleagues have included individuals with a wide range of academic backgrounds. We have combined experimental results from long path spectroscopic studies of non-criteria and criteria pollutants in polluted ambient air with those from laboratory and smog chamber experiments. These have provided a sound experimental foundation for the science involved (rates, reaction products, and mechanisms) and have provided sound databases for computer modeling simulations. Such models are also useful to assist local, state, and federal agencies in the development of air pollution control strategies, and associated risk assessments for polluted indoor and outdoor air environments.

**The Spectrum:** Glenn Seaborg regarded Blacet as one of his key teachers. Please share some recollections of Blacet and tell us what made him so special as a teacher.

**Pitts:** My personal and professional recollection of FEB as a teacher and researcher can be summed up in one bit of advice he gave Jack Calvert and me in 1946: “Theories come and theories go, but good data stand forever.” Over the subsequent decades I have tried to follow the “thrust” of his observations and found it helpful indeed.

**The Spectrum:** You had other teachers and mentors who are legends today—Albert Noyes, Philip Leighton. . .

**Pitts:** It was both a learning experience, and fun. I was a very lucky guy to be involved with three academics who were true “scholars and gentlemen”. Each had a real sense of purpose, humility, and humor, which resonated through the spectra of university research, and teaching. Actually, they would be great models for today’s younger generation of photochemists and spectroscopists.

**The Spectrum:** Take us back to that period just before World War II.

**Pitts:** Our economy was coming out of the Great Depression of the 1930s. It was the era of the Big Bands, and the development of major sports rivalries (e.g., UCLA vs. USC in any sport, especially football). Actually, I knew that all-time great black athlete, Jackie Robinson...but only “in passing”...down the halls in the UCLA gym, not the football field! Incidentally, organized baseball just celebrated the 60<sup>th</sup> anniversary of his being accepted into the Major Leagues!

Chemistry faculty were conducting excellent fundamental research, but did not yet have a Ph.D. program. However, Blacet had a strong Master’s degree program in fundamental photochemistry, for example, with students like Dave Volman (M.S. 1938) and James LuValle. Jimmy was a black man who actually ran in the 1936 Olympic Games in Berlin. That same year he graduated Phi Beta Kappa with a B.A. degree in chemistry. Then he continued on to take his Master’s degree in chemistry with The Chief.

I was a member of Alpha Chi Sigma, a chemistry social/professional fraternity, along with George C. Pimental. Incidentally, he was a star athlete in intramural sports and also a DAR. Not Daughters of the American Revolution, but rather a Damned Average Raiser! He was tough competition, brilliant, and a lot of fun! A very good guy then...as he was throughout his splendid career!

In addition to the “hardcore” courses, I took classes in tennis and golf. I loved the former, but did not “appreciate” the latter. In tennis you can always come back from being down love-40. But missing a 3 foot putt in a crucial match, can haunt you forever! Incidentally, I also played tennis with Jack Roberts, as I recall, one of my p-chem readers. I played with him once. He cleaned my clock!!!

However, those sunshine days became somewhat more exciting (scary) when in the fall of 1940, President Roosevelt signed the National Selective Service Act. It passed Congress by one vote and signs showed up all over the UCLA campus reading *OHIO (Over the Hill in October)*. Our president also found a way to send 50 of our “obsolete” destroyers to Winston Churchill in the famous Lend Lease Act of 1940.

Then came one of those moments you remember vividly for the rest of your life. Around noon on December 7, 1941, while I was writing a p-chem lab report, my mother came in and said, “Jim, the Japanese have bombed Pearl Harbor.” I knew instantly those “Days of Wine and Roses” were over... BIG TIME!

**The Spectrum:** How did the war change academic scientific research?

**Pitts:** In early 1942, a curious phenomenon occurred. Some faculty and certain graduate students in chemistry started disappearing from UCLA. Why and where they went, I didn't have a clue. In those days, security was really tight. Warnings to that effect were everywhere, for example, "Loose lips sink ships!" I later learned that they had gone to such places as the University of Chicago and MIT. We wondered why.

In any case, I continued my classes and hoped that I could be around long enough to graduate in December at the end of the fall semester of 1942. Recall that I enrolled midyear of 1939. While this was my hope, it was not necessarily my expectation. Draft notices were flying and the war hit our country very heavily in all respects.

My concern over graduating that fall vanished when in late June of 1942 I received a phone call from Dr. Blacet. He had "disappeared" earlier in the year, and it turned out he was calling from Northwestern University in Evanston, Illinois. He stated that he was conducting some interesting research at the new Northwestern Technological Institute on campus. I didn't have a clue what the research was, but when he asked me if I would like to join his team, I was thrilled to say yes.

Being a typical Southern California guy in that era, it was my first train ride ever. It took 48 hours, sitting up on a seat, to go from LA to Chicago. The highlight was when I woke up somewhere in Iowa and it looked like I was in another world, everything was green and there wasn't a mountain, or even a good-sized hill, in sight. When I left Southern California, almost everything there was brown.

**The Spectrum:** And when you arrived in Illinois, you found yourself working on military research.

**Pitts:** When I met Dr. Blacet the morning after I arrived in Evanston, he revealed to me the nature of his project. I was sworn to secrecy and became a member of Section B-6 (subsequently Division 10) of the National Defense Research Committee, NDRC. The formation of the NDRC was one of the most important acts of WWII. It was put forth, although possibly or probably in secret, by Franklin D. Roosevelt on June 27, 1940, one and a half years prior to Pearl Harbor. Once again, the foresight, cunning, and brilliance of FDR, struck me full force.

**The Spectrum:** What was NDRC?

**Pitts:** Let me read from FDR's mission statement for NDRC, again, written 18 months before the U.S. was at war: "The

Committee shall correlate and support scientific research on the mechanisms and devices of warfare, except those relating to problems of flight included in the field of activities of the National Advisory Committee on Aeronautics. The NDRC shall aid and supplement the experimental and research activities of the War and Navy Departments, and may conduct research for the creation and improvement of instrumentalities, methods, and materials of warfare."

**The Spectrum:** Was NDRC a paper committee, or actually at work before the war?

**Pitts:** The first official meeting of the NDRC was held in Washington on July 2, 1940. As described by Noyes, "Dr. Vannevar Bush, President of the Carnegie Institution of Washington, became the first Chairman of NDRC and Dr. James Bryant Conant, President of Harvard University and an eminent organic chemist, agreed to organize Division B and be its first Chairman. Division B, my Division, had the somewhat awe-inspiring title of "Bombs, Fuels, Gases, Chemical Problems."

Noyes pointed out, "In spite of the state of mind of the country, the response of scientific men to invitations to serve was immediate and enthusiastic." Our work was highly classified, and I was sworn to secrecy. Guess who I found at the "Tech Institute?" Dr. David Volman. After leaving UCLA, he had taken his Ph.D. at Stanford with Professor Phillip A. Leighton.

Actually, Blacet had also taken his Ph.D. from Leighton at Stanford in the early 1930s. So now we have two additional eminent photochemists entering and impacting my life, Noyes and Leighton. Both of them had been conducting "pure" academic research, and just completed their classic book, *The Photochemistry of Gases* (Reinhold Publishing, 1941). Incidentally, as I sit here today, I am holding my 1966 Dover Publishing copy of their book. The inscription reads, "To Jim Pitts, With warmest regards. W. Albert Noyes, Jr." As a "note in passing", in September of 1946, after the war, I returned to UCLA and took my Ph.D. with "The Chief".

**The Spectrum:** Where could interested readers get more information on these secret wartime projects?

**Pitts:** I would suggest three major sources of information on the wartime activities of a huge range of secret war projects. This is where one should look for input on all types of weaponry, "Bombs, Fuels, Gases, Chemical Problems".

Two of these were produced through the Office Of Scientific Research and Development (OSRD) as part of



a series, *Science in WWII*. The most relevant to my comments is *Chemistry: A History of the Chemistry Components of the National Defense Research Committee, 1940-1946* (Little, Brown and Company, Boston, 1948). In addition to editing the entire book, Noyes wrote the chapter most relevant to my story, "Offensive Chemical Warfare and Related Problems".

Other books are: *Combat Scientists* (Little, Brown and Company, Boston, 1947), also part of the OSRD series and *The Chemical Warfare Service in World War II* (Reinhold Publishing Corporation, 1948).

**The Spectrum:** Getting back to your war-time research.

**Pitts:** Our work at the Tech Institute was highly classified. There was complete security in all of our labs. They had been home to normal chemistry labs, but were now the home of secret research by Blacet's group on improving the activated charcoal that was being used in the U.S. Armed Forces gas masks (Figure 1) Our mission had a very high priority!

**The Spectrum:** What was the problem with gas masks at that time?

**Pitts:** It was a serious problem. Masks that had been transported into the tropics were returned for testing. The high humidity in transport and in the jungle had soaked the charcoal and rendered it *totally ineffective in trapping phosgene, COCl<sub>2</sub>*, a highly toxic gas that the Japanese were known to possess. Since these masks were identical to those issued to our troops who landed on Guadalcanal, they would have been completely ineffective had the Japanese launched a phosgene attack.

Our group, including Dave Volman, dramatically improved the Army's existing "Whetlerite", which the U.S. Chemical Warfare service (CWS) said, ensured protection against chlorpicrin, phosgene, and the vapors of mustard and lewisite. Thus, we discovered that certain elements added to the surface of the Army's existing Whetlerite solved the phosgene humidity problem and made the gas mask equally as effective against cyanogen chloride, arsine, and hydrocyanic acid (*The Chemical Warfare Service in World War II*). In taking on this problem, the Ph.D.s in the Chief's group had the fun of looking at a periodic table and testing a number of different elements, and came up with a winning combination that used copper, chromium, and silver.

**The Spectrum:** How did working with that exalted group of Ph.D.s change you, personally?

**Pitts:** It produced a *life-long* decision for me. While those guys were having all the fun, the lowest man on the totem pole—me—who did not even have a Bachelor's degree, had to personally sieve all of the charcoal being used in their experiments. I went home night after night, black in face and body covered with fine charcoal dust. I decided there and then *that if I were to stay in chemistry, I would get a Ph.D. and tell others what to do!*

**Activated charcoal canister**



**Figure 1.** Early 1942 U.S. Army gas mask.

Courtesy of James N. Pitts, Jr.

**The Spectrum:** An important insight, indeed! What else did you learn?

**Pitts:** Another thing I learned early on in the Blacet Group, was the witty, sometimes ribald sense of humor that occasionally showed up. For example, my first New Year's Eve after I got on the project at Northwestern was really quite an affair. The "bash" not only left me with a significant hangover (my introduction to Scotch), but with a motto that I have found appropriate on a number of occasions personally, scientifically, and politically. There on the wall of the Evanston Hotel, was a huge placard that read: "*As Our Objectives Become More Unclear, Let Us Redouble Our Efforts To Achieve Them.*"

It carried me through the war and academia...and fortunately (or unfortunately) has at times remained relevant over the last 60+ years.

**The Spectrum:** So with the gas mask problem solved, how did your focus shift?

**Pitts:** Our group had achieved success in protecting our troops against non-persistent—gaseous—chemical agents, and for the rest of the war, our “Blacet Group” focused on the *offense*, that is, delivering gaseous chemical weapons.

As Noyes states in his chapter, “Offensive Chemical Warfare and Related Problems”, “At a meeting in Evanston, IL, early in July 1942, it was pointed out that the information available on gas concentrations which could be obtained by the use of chemical warfare munitions was very meager. Thus, the U.S. Chemical Warfare Service (CWS) had not carried out any extensive field trials since the last war. Dugway Proving Ground had recently been established at Tooele, UT (located in a remote, barren desert southwest of Salt Lake City) and was almost ready to begin operations.” This effort continued through the rest of the war.

**The Spectrum: Who headed up this program?**

**Pitts:** Phil Leighton, on lease from Stanford, was directly responsible to the Commander of the post and supervised the initial group of NDRC scientists. Clearly my academic grandfather was a success because in the spring of 1943, he was commissioned as Lieutenant Colonel, and became Director of Technical Operations at Dugway.

Incidentally, today Dugway is an enormous facility where all kinds of research programs are being conducted, unclassified and classified. I have no idea about the latter as my “clearance” for CW and BW that I held until the early 1970s, at Edgewood Arsenal and Fort Detrick, terminated around that time.

**The Spectrum: Was all of the research done in Utah at Dugway?**

**Pitts:** It became clear to Leighton that expanded field studies must be carried out on the effects of terrain and meteorology, other than those that had been conducted just on the flat, open ground of Dugway.

So, in the spring of 1943, the Blacet group, carried out experiments with SO<sub>2</sub> in cane breaks along the Ohio River. Actually, our target zone was on the farm of Conway Pierce’s grandfather in Kentucky. Pierce was also on an NDRC project. That was our first “field experiment”...and indeed was very interesting. Actually, we made our own “bombs” out of iron cylinders filled with a small internal tube. In operation, the cylinders were filled with sulfur dioxide and dynamite sticks inserted into the internal tube.

**The Spectrum: Dynamite?**

**Pitts:** Yes. So picture this: We’re out in these fields in a “home made bunker”—that’s a hole in the ground—and our first bomb, containing sulfur dioxide and six dynamite sticks is set up a relatively short distance away, about 100 feet. What a blast! Parts of trees and bushes came falling down around us, but fortunately nobody was hurt.

We subsequently reduced the “charge” to two sticks of dynamite, and no longer had to worry about shrapnel. However, on ignition and with the cry “fire in the hole”, our bomb was set off...this cylinder went up, split open but intact, and fell to earth, we knew not where. We had to choose between six sticks and shrapnel, or two sticks and an entire bomb shell falling on one of us, while we were madly “sampling” away. We chose the latter.

Between “shoots”, the “natives” in the area were friendly and our “top brass” were pleased to learn, that in fact, our first CW field tests were a success. As Noyes points out, they “showed that in locations where the wind velocity is low, high concentrations may be maintained for relatively long periods of time...indeed so long that there existed a possibility of canister penetration”!

In other words, under inversion conditions on a cold morning, sufficiently high concentrations could be reached that a gas mask could be rendered ineffective. I should note, there were a number of studies also carried out at this time by Latimer’s group at UC Berkeley and Yost’s group at CalTech. Additionally in 1943, Colonel Phil Leighton directed the first large-scale experiments in a forested area using actual bombs. The bombs were statically placed. For details, see Noyes’ chapter.

**The Spectrum: Were there other field experiments in the United States?**

**Pitts:** The next field operation of the Blacet group was a “campaign” in a semi-tropical climate. It was based in the Withlacoochee Soil Conservation Project near the tiny town of Bushnell, Florida, which had a population of 50 or 100. Dr. Dole of the Northwestern Chemistry Department was one of the early leaders of the operation.

The “shoots” were carried out with static bombs containing, among other agents, hydrogen cyanide. Our teams set forth in the swamps well before dawn to sites where our sampling instruments had been set up. We turned them on just before the ignition of the static bomb. It was quite an experience for all concerned, and valuable data were attained on the effects of terrain and meteorology, on the “impacts” of gaseous CW weapons in swamps and in jungle areas.

Actually, not only was the sound and sight of the bombs going off “thrilling”, but we also had the “fun” of walking through the swamps in the pre-dawn darkness knowing they were full of reptiles like water moccasins and all kinds of other “bad actors”.

**The Spectrum: Any need for tests in a more tropical environment?**

**Pitts:** In late 1943, the “powers-that-be” decided it was important to carry out actual tests in the tropics. A site was chosen on Isla San Jose, an island about 50 miles west off the coast of Panama. This island, one of the Perlas group, was uninhabited, and had been for almost a century. The natives thought it was haunted. That fact, plus the extremely dense tropical vegetation made it an ideal site for one of the major field operations for chemical warfare in WWII. The island is still rugged. Interestingly, three seasons of the reality television show *Survivor* were filmed there.

In order to carry out this operation, members of our NDRC group (along with fellow scientists from CalTech, Berkeley and industry) were sworn in as “Technical Observers”. Until the end of our participation in the operation, some six months later, the twenty of us wore U.S. Army Officer uniforms with a large “T.O.” on the armband.

It was an interesting situation in that we had officer’s privileges and were subject to most army regulations. We could not disclose any aspect of our mission to other members of the armed services, much less family, friends, university colleagues, destination, operations, and so forth. As I recall, our address was simply, “P.O. Box XXXX”. As is typical for a “secret” operation, all of our correspondence was censored.

**The Spectrum: Presumably, that group did not fly group to Panama in those days. Getting there must have been an adventure.**

**Pitts:** In early December 1944, we put on our uniforms and headed to New Orleans, our port of embarkation. It’s quite a place to be when you are 23 and “free”! Our “troop’s transport” was an old, 10,000 ton “Liberty Ship”, with a single 5-inch gun and some “primitive” accommodations. Even as officers, there were about 20 of us assigned to a single “cabin” with bunks three deep in a “room” about the size of a kitchen. Several hundred enlisted men traveling with us had much more crowded and uncomfortable quarters. We certainly felt sympathy for them. One morning, we finally boarded our ship that was anchored on the Mississippi River

across from New Orleans. As we did, a group of patriotic ladies offered us coffee and some goodies. We were all gung-ho to get going and were delighted to pull out into the middle of the river. All of a sudden, the anchor was dropped and *for the next four days* we stayed in the middle of the Mississippi River. Someone in “security” thought there were explosives on board, so we were stuck with the charm of New Orleans on the horizon...unable to go ashore. Finally, we headed down the Mississippi with the goal being Panama City. Let me insert at this point another “truth” about the army that I also found very applicable to a number of aspects of civilian life. The old saying was, “Hurry up and wait!”

Our “cruise” down to Panama was fascinating. On the way we docked at a place I had never heard of, Guantanamo Bay. There were rumors of German submarines in the area, but we never knew why we stopped there. After a couple of days we headed to Puerto Rico and docked at San Juan.

**The Spectrum: You picked up more passengers there?**

**Pitts:** Yes. Goats. About one hundred goats were “deck loaded” on our ship, the *William M. Evarts*. They were to be used as live “detectors” in our field trials of CW weapons on San Jose Island. However, someone in Army brass decided they would also be our companions throughout the entire trip back to Guantanamo Bay and ultimately through the Panama Canal to Panama City where we “all” disembarked only to meet again on Isla San Jose. Given the nature of our co-passengers what a great Caribbean cruise it was...a bit “sticky and stinky” but “c’est la guerre”.

While in San Juan, I had the remarkable opportunity of going to a unique U.S.O. affair at a big hotel. It turned out that the guest of honor was none other than Eleanor Roosevelt! There was a long line of G.I.s waiting to shake her hand. She was stunning in a beautiful dress and I still remember when I walked up she shook my hand and asked, “What is your name?”, and I answered, “Jim Pitts”. She asked where I was from, and I told her I was from Los Angeles. She then said, “Well, Jim, Franklin and I are deeply appreciative of the sacrifices all of you are making for our country.” As I saluted and walked away, I was on cloud 9 and go back to that time in my mind whenever I think of her.

**The Spectrum: What operations were conducted when you reached Isla San Jose which I understand was 14,000 acres of jungle, forest and beaches?**

**Pitts:** It was our job to set up a variety of sampling instruments in the dugouts that the army had constructed in



various types of jungle terrain. Aircraft flew over in formations of about 6-8 planes. Each of them generally dropped at least five 1,000 pound bombs loaded with a CW agent. We would turn on the instruments in the dugouts, retreat back to an area behind another set of dugouts and watch the bombs come down and explode. We would then go back to our instruments and go to work.

Of course, we donned our masks prior to the bombs leaving the planes! When they struck the ground they created a huge cloud of gas. Agents that we tested included phosgene,  $\text{COCl}_2$ , hydrogen cyanide, HCN, and a highly toxic secret agent, cyanogen chloride,  $\text{CNCl}$ .



Goat with gas mask for field tests



"Mechanical Goat"

Figure 2. 1944. Monitoring outdoor and indoor air, chemical warfare style.

Courtesy of James N. Pitts, Jr.

**The Spectrum:** And so bring in the goats?

**Pitts:** The function of our shipmates, the goats, was to serve as live detectors during the "shoots" of each of these three agents. They were fitted with gas masks that had containers filled with either U.S. "Whetlerite" (our state-of-the-art

activated charcoal), or charcoal from captured Japanese gas masks. Some of the goats had no masks at all (poor guys!). You can imagine that while we were running our sampling systems in the middle of a gas cloud, we sure as hell kept our eyes on the goat wearing the American mask...our ultimate detector.

Interestingly, concurrent with these field tests back in the States, members of Blacet's group actually designed, built, and operated mechanical goats. They had all the respiratory characteristics of the "real thing". Sure made the goats real happy (Figure 2).

**The Spectrum:** Were there any mishaps with all that bombing, and living in jungle conditions?

**Pitts:** In one case the planes dropped 1,000-pound bombs filled with "plain old butane". This run was made to test a new type of "hot wire" detector developed at Berkeley by a "senior" member of our group, Bill Gwinn (actually Bill was second in command of our operations after Blacet). Unfortunately, the "shoot" was carried out during the dry season. The butane caught fire, and a significant part of the jungle began to burn. We had a hell of a time! After that, Gwinn got the nickname "Butane Bill".



Figure 3. One of our companions on Isla San Jose.

Courtesy of James N. Pitts, Jr.

Incidentally, in passing, Gwinn was a really nice guy who occupied a tent directly across from Chet O'Konski and me. One morning we looked across and watched him do a "war dance". It turns out he had pulled up his pants with a scorpion resting inside of his trouser leg and it had nailed him just below a very important part of his anatomy. We couldn't

help but laugh at him. Bill pointed out that he was too old to cry, but it hurt too much to laugh. Just another vignette. After that, he learned to always turn over and tap his shoes before getting dressed in the morning.

Scorpions were just one of the many interesting “challenges” we encountered sleeping, walking, and crouching in a fox hole, in a really thick jungle. Figure 3, for example, shows one of our companions on Isla San Jose.

**The Spectrum: And the field tests generated important data?**

**Pitts:** Some very important information emerged in August and September 1944. As Noyes described it, “Several attacks were performed under operational conditions with the aid of the Sixth Air Force on a scale which, as far as we are aware, was never equaled in gas experiments during this war. The data obtained were more complete than those ever obtained before. A large amount of credit for organizing the non-persistent phase of the program is due to Dr. Blacet, but the entire group with him, 20 very able men, performed outstanding service under conditions which were at times exceedingly trying.” (See Figure 4. See Noyes’ book for a full list of names.)

**The Spectrum: And it was done under difficult conditions.**

**Pitts:** We all developed additional respect and affection for all members of our armed forces who were engaged in jungle warfare throughout the Pacific. Our hearts went out to those guys who not only had to live under these conditions, but engage 24 hours a day in mortal combat with our enemy. They were all true heroes and have had my undying respect to this day.

**The Spectrum: Was Noyes in Europe during the war?**

**Pitts:** Yes, and it illustrates, once again, his vision and courage. W. Albert Noyes, Jr.’s mission in the European Theatre was to interview Frenchmen who had actually worked for the Germans in one capacity or another. Following the

Germans retreat across the French-German border, the Frenchmen were more than eager to describe their experiences to Albert.

Let me quote from the book, *Combat Scientists*:

“Dr. W. A. Noyes, eminent chemist and Chief of Division 10, who had studied and lived in France for some time, went over to Paris as an ALSOS investigator to look into these possibilities. He reported that the Germans had used the French scientists only in minor ways and that we could not expect

to get much useful information until we could set foot on German soil ourselves.

“He also concluded from conversations with the French that the Germans were loath to use poison gas. He reasoned that they probably had significant developments in this field but would recognize that we must have also. They would therefore be afraid of reprisals.”

“The soundness of Noye’s deduction was amply demonstrated later when our investigators found large quantities of German gas munitions and uncovered secret formulas of new and far more deadly poison gases than had been used in World War I.”

**The Spectrum: When did you get back to school?**

**Pitts:** My activities on Isla San Jose along with many others in our team ended, as I recall, around mid September 1944. Francis Blacet and W. A. Noyes, Jr., had thoughtfully arranged that I fly back to Los Angeles where I took off my TO uniform and explained to my parents and friends that



**Figure 4.** The Isla San Jose “Blacet team” in 1944. Bottom row left to right: D. Volman, number 1; R. Dickinson, number 3; F. E. Blacet, number 4; W. Gwinn, number 5. Middle row left to right: R. Brinton, number 1; C. T. O’Konski, number 7. Top row left to right: G. Doyle, number 1; J. N. Pitts, number 3.

Courtesy of James N. Pitts, Jr.



my yellow skin was due to the antimalarial drug we took, not to some loathsome tropical (or other) disease. I joined Professor Anton Burg's group at USC on another related but classified project, dealing with finding chemical stabilizers that could be added to our chemical loaded bombs stored in the South Pacific.

This was a useful nine months with interesting experiences not only in the lab but (1) playing tennis at noon with a young Sid Benson and (2) going to classes at night to UCLA, finally getting the 5 or 6 units needed to get my B.S. degree in June 1945. That explains the gap in my CV; I entered UCLA in winter of 1939 and graduated Phi Beta Kappa in 1945.

I returned to Northwestern University and spent the next year with Professor Frank Gucker's group doing classified work developing a new and unique forward scattering (as opposed to right angle) fine particle counter. Chet O'Konski led the way to success that pleased the BW group at Fort Detrick...and led to my first paper that appeared in the *JACS* in 1946. In the fall of 1946, I packed up and headed back home to Westwood, I entered graduate school at UCLA in the Chemistry Department in September of 1946, and went back to the basement lab of the Chief. I had a keen interest in gas phase photochemical processes, stimulated, in part, by Noyes and Leighton's classic book, *Photochemistry of Gases*, published in 1941.

Those were great days. Our laboratories were in the sub-basement of the Chemistry Building, with no windows, one door and only one way in and out. It was there that Jack Calvert (who had just gotten out of the Navy) and I met and spent the next three years together, often night and day. We were continuing "The Chief's" war-interrupted research on the gas phase chemistry of aliphatic aldehydes.

A key state-of-the-art advance was our ability to analyze the gas phase photolysis products of these and other volatile aldehydes with a newly developed mass spectrometer that had been given to The Chief by Signal Oil Company the year before. They had used it in their war-time studies of synthetic rubber, and subsequently donated it to UCLA.

Bob Brinton, an old friend who had also been a key member of our "Blacet team" had come out of the OSRD in the fall of 1945 and gone directly to UCLA. In initiating his study with The Chief, he got the mass spectrometer assembled and up and running. What a guy! It was a pioneering instrument using a galvanometer with a light beam moving across a curved meter stick about eight feet long. We had to dial in each peak manually, so a product analysis could take hours. However, it delivered clear spectroscopic identification.

The cooling trap had to be kept full at all times, so Jack and I took turns showing up around midnight to fill the trap(s) with liquid nitrogen or dry ice. This was not all bad because it gave us an opportunity to b.s. with the other graduate students also there late at night. Actually, it really was the "*nights of wine and roses*" because you ran into all kinds of researchers, young and old, and had opportunities to discuss a variety of topics from sports to science.

#### **The Spectrum: Was George Hammond there?**

**Pitts:** George had just entered as an incoming postdoc. Don Cram had just come in as a new member of the faculty. As I recall, George was working with Saul Winstein. They boosted my existing interest in mechanistic aspects of physical organic chemistry, and in turn I think they developed an appreciation of the gas phase photochemistry of organic compounds (e.g., aliphatic aldehydes) as an interesting new field. Both Don and George were brilliant, and their great success in future years, including Don's Nobel Prize, were not at all surprising to me.

Those good times were followed by interactions with them over the years as, for example, from 1949 to 1954, when I was at Northwestern, as an Assistant Professor of Chemistry, and George was in a similar capacity at Iowa State. Ultimately, they led to our joining Albert Noyes in initiating and becoming co-editors of *Advances in Photochemistry*.

I took my Ph.D. in 1949 and was invited to return to Northwestern as an instructor, and subsequently an assistant professor, in chemistry. That was one of the most challenging, fulfilling and fun periods of my entire academic life. It was a great department, with senior faculty actually keeping a close eye on—but always being helpful to—the young faculty, such as me. For example, everyday at noon, a large part of the department faculty, young and old, got together for lunch. These bag lunch bull sessions were educational, covering a wide range of topics, academic, sports, political (university and national), and just plain gossip.

I kept my mouth shut and listened, and learned a lot about the whole ball game. It was there that I initiated research in solution phase photochemistry, along with a gas phase program and coulometric titrations with Don Deford.

On a personal note, two of my three daughters were born in Evanston, and the third shortly after I arrived in Riverside in 1954. Being at Northwestern was a heck of an experience, and many a time I wished I had gone back...they actually asked me to. But, being a California boy I wanted to stay where there were mountains, a trout stream, and the ocean nearby...a totally different environmental world than

Evanston, Illinois, on an often frozen Lake Michigan in a heavily populated region about 15 miles north of Chicago.

It was with genuine regret that, in the fall of 1954, I left Northwestern, in order to join Conway Pierce and others in the founding of the new Riverside Campus of the University of California, UCR.

**The Spectrum: Was it a smooth transition?**

**Pitts:** On arriving I got my first shock, when the new Chancellor, in response to my questions about starting to recruit graduate students, informed me that UC Riverside would not even have a graduate school. We would instead focus totally on an undergraduate program, sufficiently strong, that UCR would be known as the “Swarthmore of the West”. That night I went home and got loaded!

I was unhappy, but in any case my die was cast. I had to make due with a very difficult situation for me, philosophically and professionally. As a consequence, from 1954-1958, UCR functioned like a liberal arts college. In lieu of recruiting and having graduate students, I really had to focus on undergraduates and postdoctoral fellows.

**The Spectrum: And you had some extraordinary students?**

**Pitts:** A prime example is Richard R. Schrock (Figure 5), a 2005 Nobel Prize Winner. In his lecture, “Multiple Metal-Carbon Bonds for Catalytic Metathesis Reactions”, Rich was kind enough to write:

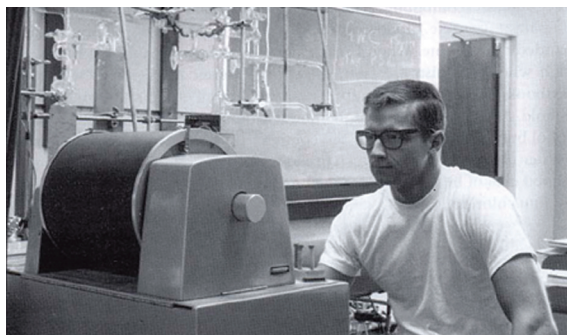

**Figure 5.** Nobel Laureate Richard R. Schrock conducting research as an undergraduate at the University of California, Riverside, in the group of James N. Pitts, Jr., in the mid sixties.

Courtesy of James N. Pitts, Jr.

“The only financially viable option was the University of California. I was accepted at Berkeley but chose to attend

Riverside, a relatively new campus about 90 miles north of San Diego, because I thought that a smaller school might allow me to do more independent research earlier in my career. That proved to be the case. After the first exam in my first chemistry course at UCR, I was approached by Professor James Pitts who asked if I wanted a summer job. I agreed and began research in what broadly could be called atmospheric chemistry, a hot topic in the smog ridden Los Angeles basin and surrounding area at that time. In actuality, I spent my time learning to blow glass and construct vacuum lines, and to measure low concentrations of photolysis products using a temperamental, delicate, almost impossible to align, multi-pass Perkin-Elmer IR machine connected to a vacuum line. (Fourier Transform machines were not yet known.) A paper entitled ‘The Detection of Ethylketen and enol-Crotonaldehyde in the Vapour-phase Photolysis of *trans*-Crotonaldehyde’ reported some of my work in 1968 after I had moved on to graduate school.”

I was deeply moved to read these comments and his handwritten note on the cover (see Figure 6).

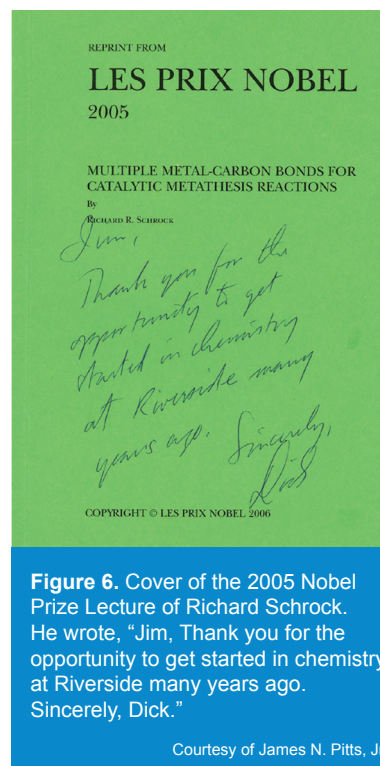

**Figure 6.** Cover of the 2005 Nobel Prize Lecture of Richard Schrock. He wrote, “Jim, Thank you for the opportunity to get started in chemistry at Riverside many years ago. Sincerely, Dick.”

Courtesy of James N. Pitts, Jr.

**The Spectrum: How did your career change at Riverside?**

**Pitts:** I continued some research in photochemistry that I had initiated at Northwestern, including studies on the

solution phase reactions of ketones, for example, benzophenone and set up hi vac systems and started investigating gas phase systems. I also served as a consultant to the Advisory Council Army Chemical Corps (1952-1965) and was “active” in campus affairs, becoming the first Department Chair in 1961.

In the latter capacity, to seek candidates for new faculty positions, I called Bill Gwinn (NDRC colleague in San Jose) at Berkeley and for physical chemists he recommended a young “Dr. Chan”. Don Cram at UCLA suggested Fred Hawthorne as an inorganic chemist. We hired both—they were very successful and were subsequently “stolen” by Cal Tech and UCLA where they are having outstanding careers!!!

Along the way, in 1958, I spent several months as a “Visiting Professor” at the Shell Development laboratories in Emeryville, California. I gave a “Short Course in Photochemistry” and collaborated with some of their researchers studying the radiation chemistry of ketones. “Good Show.” I learned a lot about industrial research from some very talented and nice people on their team.

**The Spectrum: Did any of those contacts result in collaborations or lasting friendships?**

**Pitts:** It was there at the “Red Garter” in San Francisco, which featured a “hot” banjo band, that I met a neat guy, Brian Smith, who was postdoctoring with Professor Hildebrand at UC Berkeley. Over the years we interacted—in 1961, in the Physical Chemistry Laboratories (PCL), and on the tennis courts of Oxford, where I was on a Guggenheim Fellowship spending a sabbatical working with E. J. Bowen, author of the 1946 classic *Chemical Aspects of Light* (Oxford University Press, 2<sup>nd</sup> ed.).

Subsequently, Brian visited me at UCR, where we continued our tennis “activities” and collaborated on a paper on an interesting subject, especially in smoggy southern California, “Singlet Oxygen in the Environmental Sciences. Role of Singlet Molecular Oxygen in the Production of Photochemical Air Pollution” (*Environ. Sci. Technol.*, 1967, 1, 656-657).

I’m very pleased to report that his experiences with me on the courts and in “smog science” did not tarnish his subsequent brilliant career in the worlds of science and academia. For example, it was an honor indeed to introduce he and his charming wife, Regina, as Sir Brian and Lady Smith when they visited us in July 2006 and toured Barb’s AirUCI Institute at UC Irvine. He had recently been knighted by the Queen!

**The Spectrum: What question do you wish we had asked?**

**Pitts:** One of them is: “What advice do I have for new, incoming men and women graduate students, postdocs, research scientists, and faculty, including instructors and visiting professors taking on their first position or appointment in a chemistry department located in a major research oriented university or college?”

**The Spectrum: And the answer is. . .**

**Pitts:** My specific advice: Don’t try to “pull your rank” when dealing with departmental staff, and technical staff, such as machinists, glass blowers, computer “jocks” as well as university-wide staff in “Buildings and Grounds” such as plumbers and electricians. They are experts in their fields and have pride in their abilities and accomplishments. If they feel insulted or demeaned, they can really “screw you” ...and any other egotistical and impolite, loud-mouth academic—graduate student or professor.

Jack Calvert and I coauthored a book in 1972 (with George Dorian) titled *Guide to Graduate School in the Sciences* (Wiley) that discusses these important, but often overlooked aspects of how to thrive in a scientific career.

**The Spectrum: Are their ways to cultivate these individuals?**

**Pitts:** Yes. Get smart. You’d be surprised at the benefits if you bring, for instance, a woman Administrative Assistant a birthday card or maybe even flowers or candy...even if she hadn’t done you a special favor, for example, straightened out your time chart or budget proposal...and especially if she has. The glass blower or machinist who constructs for you a special, complex piece of apparatus will rarely refuse a “thank you”, accompanied by a bottle of good wine. Do you guys and gals get it????

A prime example of this “philosophy” occurred during our “tropical island holiday” bombing the hell out of the jungle. As TOs we scientists had officer status, but the question of “who’s in command” was complex...a situation some regular army men under General Bullene had questions, concerns, and gripes about early in our campaign.

As low man on a complex totem pole, I don’t know what caused the rebellion of many of the army enlisted men when one day they refused to carry sand bags up to our sampling dugouts. They said we couldn’t order them to do so.

**The Spectrum: How did Blacet respond to that situation?**

**Pitts:** I'll never forget! Right in the middle of the dense jungle foliage, Blacet said, "OK fellows, let's go." And he threw a heavy sand bag over his shoulder and started up the steep hill to the holes in the ground that had to be converted into reasonably secure sampling sites. We all immediately picked up bags from a huge pile, threw them over our shoulders and followed "El Jefe" up the hill to the sites and laid them out in appropriate protective patterns.

The G.I.s stood by and watched us head up the hill. We never had to ask them again! We didn't "pull our rank"—whatever that was—and they respected us for it. No more problems for the rest of our stay.

A short hand way of saying the above was the advice given to me by an officer in the regular army who'd been through the wars...*"Take care of your sergeant and he'll take care of you."*

**The Spectrum: Which of the scientific books you coauthored required the most effort?**

**Pitts:** All three of them—one on photochemistry with Jack Calvert and two on atmospheric chemistry with Barbara. They did most of the work...I was a "useful" coauthor. The reference book, *Photochemistry*, which Jack Calvert and I wrote, published by Wiley in 1966, was a long haul, probably over five years and two sabbaticals at Oxford at University College in 1961 and Merton College in 1965. Hopefully, the years Jack and I spent grinding out that "expletive deleted" book were worth it. At least some Russian scientists seemed to think so.

**The Spectrum: Russian scientists?**

**Pitts:** In October 1975 Jack and I and four other U.S. scientists, experts in various aspects of air pollution/ atmospheric chemistry, were asked by the U.S. State Department to go to Leningrad and Moscow as members of the U.S. delegation of the Joint US/USSR working group on Air Pollution Modeling, Instrumentation, and Measurement Methodology, EPA, Leningrad/ Moscow, October 18-November 2, 1975. We replied, "We want to cooperate and be of any assistance we can, given our experience with, for example, "L.A. Smog". Well, in one sense, we had already "assisted" them, but didn't realize it until about two weeks before departing to Leningrad. Jack called me and said, "Guess what, an East German book dealer just contacted me and asked 'Would you like to buy a copy of Calvert and Pitts in Russian?'"

Thanks a lot! We never knew they existed and no one asked us for permission to copy it.

**The Spectrum: Did you work with Russian scientists?**

**Pitts:** Three decades later as a happy and relevant follow up to this story, over the last several years with Barb's AirUCI, I have had the pleasure of occupying an office a couple of doors down the hall from a splendid young Russian scientist, Sergey Nizkorodov. He has proven to be not only a brilliant imaginative researcher in spectroscopy/ photochemistry, but also a fine, inspiring teacher of undergraduate and graduate studies alike, and a wonderful colleague and friend. Indeed, last week he was awarded a 2007 Camille Dreyfus Teacher-Scholar Award.

Over the years, and a few glasses of red wine, he and I have had some really fun bull sessions on a variety of hot areas of atmospheric chemistry, fundamental and applied, including several in the area of the chemical, physical and health impacts of widely sold home air purifiers. The advertisements say you just put them in your living room, bathroom, and so forth, turn them on and your household air will be fresh and odor free.

Well for many manufacturers and models, it "just ain't so". They actually produce ozone that dulls one's sense of smell, so everything smells good! It's a long story, but for references and details, see his and his coworkers recent article, "Kinetic Analysis of Competition between Aerosol Particle Removal and Generation by Ionization Air Purifiers" (*Environ. Sci. Technol.* 2007, 41, 2498-2504).

**The Spectrum: What advice do you have for scientists in staying active and productive in the later stages of their careers?"**

**Pitts:** I say, "Keep active in your science and your sports!" Don't retire your brain, imagination, and zest for learning just because you have retired from your position of many decades. There's a world of science out there that needs old pros like yourself and it's a real kick to continue to be involved in probing "Mother Nature".

As another example, two of my next door neighbors at my office in AirUCI are chemists. They served for some three decades as faculty members and administrators at Orange Coast Community College, Michael Ezell as Department Chair and Stan Johnson as Dean of Math and Science. These guys haven't retired from science by any means.

They are key members of Barb's research team, old pros to whom the younger members of her group turn to for



advice when “that damn spectrometer” fouls up, or “how do you interpret these results from our mass spectrometer?”. We all appreciate their scientific talents, sense of humor, and all-around wisdom.

So in short, my advice is that you can retire from your long-term professional position. But don't retire from your professional life! As another WWII vet told me when I asked, “How did you get out of that jungle hell hole alive?” His response: “Sir I learned fast. Keep moving, they can't draw a bead on you!”

Let me close this section with the following quote. It applies to all of us:

When the world famous Helen Keller (1880-1968), blind author and lecturer, was asked, “What could be worse than losing your sight?” She replied, “*Losing your vision!*”

**The Spectrum: What are your personal views on the critical roles played by research in photochemistry and spectroscopy in attacking one of the major, long environmental threats of our times, photochemical air pollution.**

**Pitts:** It has been over a half century, since the tragic London “smog” (smoke and fog) in 1952 caused some 12,000 early deaths, and the appearance, actually recognition, in the early 1950s of a new atmospheric phenomenon, L.A. smog. Over the last half century we have come to recognize photochemical air pollution can, and definitely has severely impacted the health and welfare of our general population, especially children, as well as our agriculture and our environment in major urban/suburban areas throughout the world, for example, Mexico City.

Furthermore, today we have another new scientifically and politically “hot” atmospheric phenomenon, global climate change. These areas are addressed under our discipline of Atmospheric Chemistry, however, I shall focus on the former which was, and remains “my ball game”.

Another type of air pollution is also man-made...the use of highly toxic chemicals to kill living organisms, for example, the widespread use of pesticides in outdoor agriculture and indoor home fumigations. This category of hazardous air pollutants (HAPs) also includes chemical warfare agents. We'll briefly discuss this topic at the end of my remarks.

Let's go back and state the problem, in the eyes of the public, for example, the first official meeting of the new Southern California Section of the ACS in 1911 was titled “Our Smoke Nuisance” and was about “the basin's problem with atmospheric haze due to smoke particulate”. Some 40 years later, another observation is made by Nobel Prize

winner James D. Watson in his book *Genes, Girls, and Gamow: After the Double Helix*.

“...My parents drove me to Midway Airport for the long flight to Los Angeles...I felt pleasantly important until dirty yellow smog enveloped the plane as it descended over the mountains above San Bernardino to enter the Los Angeles Basin. The acrid stench, which greeted me as I left the plane and rode through the palm tree-lined streets into central Los Angeles, grew even viler as the taxi ascended the Pasadena Freeway. In Pasadena, we turned off towards the Caltech campus, sited just north of the San Marino mansions...”

On February 19, 1953, Kenneth Hahn, a powerful Los Angeles County Supervisor, wrote the Presidents of General Motors, Ford, and Chrysler “regarding the automobile industry's obligations to meet its rightful responsibilities in controlling air pollution from automobiles... Are there any devices which can be attached to automobile exhaust manifolds or pipes which would effectively reduce exhaust gases?”

**The Spectrum: And his response?**

**Pitts:** The reply from the news department of Ford Motor Company was: “The Ford engineering staff, although mindful that automobile engines produce exhaust gases, feels these waste vapors are dissipated in the atmosphere quickly and do not present an air pollution problem.” General Motors replied in a similar manner, and as I recall Chrysler did not respond.

At CalTech, A. J. Haagen-Smit and M. M. Fox of the recently formed Los Angeles County Air Pollution Control District carried out a series of experiments based on the ability of ozone to crack rubber bands. One puts stretched rubber bands into a large flask and introduces clean air with (a) auto exhaust in air or (b) various VOCs and NO<sub>x</sub> in air...and irradiates the system with simulated sunlight.

After a year or so of experimentation, they concluded that: “The concentrations of ozone formed, as well as the concentrations of exhaust gases used, are of the same order as those measured in Los Angeles atmosphere. These investigations show that automobile exhaust gases are capable of forming ozone in the air and are therefore to be considered as a definite source of smog.” (*JAPCA* 1954, 4, 105)

Well, as one can imagine there were comments about “it's not the rubber bands that cracked...it's the professor”. Furthermore, based solely on wet chemical (bubbler) analytic techniques, some questioned the actual presence of significant amounts of ozone in Pasadena air. Now here's where the “age of spectroscopy” really began, and as we shall



illustrate, over the decades has grown to be a remarkable, invaluable qualitative and quantitative tool, not only for fundamental research, but in its application to establishing sound data bases for air pollutants whether in smog chambers or outside air.

Such information has been crucial to the establishment of sound legislation at the local, state and national levels and robust, reliable, health-based air quality standards for ozone and its associated pollutants, including “Pandora’s NO<sub>x</sub>” described earlier. This was a term I started to use from my early days as Director of the Statewide Air Pollution Research Center (1970-retired 1988). Actually, I was a cofounder of SAPRC in 1961, along with two of the real discoverers of photochemical smog, the internationally recognized plant scientists John Middleton and Ellis Darley.

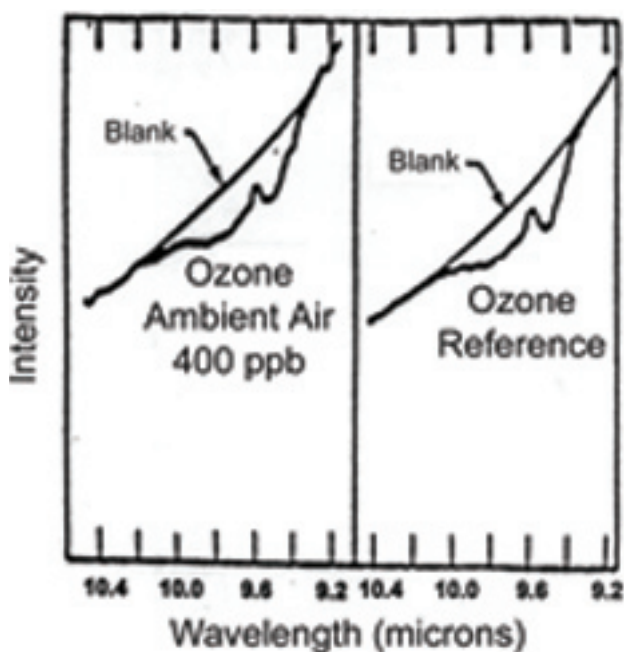

**Figure 7.** First long path infrared spectroscopic identification and measurement of ozone in polluted ambient air by Stephens, Scott, Hanst and Doerr (1956).

Courtesy of James N. Pitts, Jr.

Now let’s go back to South Pasadena in the mid-1950s and see the conclusive blow to the often used argument, “You can’t prove it’s really ozone in smog”. Well look at Figure 7, the “clincher”.

This “spectroscopic kill” established without a doubt that the people living in South Pasadena on the afternoon of September 28, 1956, were exposed to 400 parts per billion (ppb) of ozone in their outdoor ambient air.

Talk about the health impacts! That is more than four times California’s 1-hour Air Quality Standard of 90 ppb. Indeed it is double our first stage ozone alert level of 200 ppb.

Starting in the 1960s, and going into the 1970s, when these levels (200 ppb) were reached, all outdoor activities of K-12 students were cancelled. Students had to stay indoors until late in the afternoon or evening when the ozone levels dropped below 200 and the alert was cancelled. In some parts of Southern California there were over one hundred days per year when such alerts were called. Today there are of the order of one or two per year. Controls work!

The scientific integrity of the data base proved critical when in the 1960s the state of California made a crucial policy decision. It mandated health related air quality standards as the foundation for developing air pollution emission control strategies, regulations, and so forth. This was in direct contrast to the approach of many other countries. For example, Britain, France, Germany, and so forth stipulated use of the best available control technology (BACT) in developing their air quality standards, emission controls, and so forth. This is a major difference in the way the nations of the world developed and implemented their air pollution emission control standards for ozone and its co-pollutants.

Now, let’s go back to the ozone argument of the early 1950s... Is or isn’t ozone present in Pasadena Smog? How can one establish an air quality standard for O<sub>3</sub> if it isn’t even there? If it is there, how is it formed? Now here’s where history strikes again, and is highly relevant to this interview. The two key players in the early days, the 1950s, of this kind of urban/suburban “chemical warfare”, were two of the three photochemists to whom I dedicated this interview, Francis Blacet and Phil Leighton. These leaders in fundamental gas phase photochemistry in the 1930s and the chemical warfare program of WWII went on to be pioneers in the “L.A. Smog Wars”. Blacet postulated in 1952 that photochemical decomposition of NO<sub>2</sub> in sunlight was the source of ozone in the polluted troposphere. Leighton, co-author with Albert Noyes of the 1942 classic *Photochemistry of Gases*, wrote the 1961 “bible”, *Photochemistry of Air Pollution* (Academic Press, 1961). The thrust of the preface to his book was, and remains today, so “on target”:

“One of the most striking developments of the past decade, both in the field of air pollution and in that of atmospheric chemistry, has been the recognition that photochemical reactions, produced by sunlight, may convert relatively innocuous pollutants into substances which constitute a nuisance, create a possible health hazard, and cause economic loss to man.”

**The Spectrum: Hence the need existed for the University of California Statewide Air Pollution Research Center?**

**Pitts:** The UC System needed a research-oriented center dedicated to carrying out basic research on atmospheric systems...for example, spectroscopy/photochemistry that would be the foundation to new health-related and cost-effective solutions to this ever growing disaster...one that was becoming worldwide in scope.

From its conception, SAPRC's challenges included:

- Understanding sources, reactions, and sinks of photochemical air pollution (e.g., L.A. smog) on local, regional and global scales.

- Development and validation of sophisticated air pollution models containing heterogeneous (surface) reactions as well as traditional gas-phase processes.

- Use of long path spectroscopy for generation of data used in generation and implementation of risk assessments and control strategies for ozone, acids, toxics, and particles, that are both health protective and environmentally sound.

Our overall approach was to view these challenges from the perspective of The Air Pollution System (Figure 8)... with emphasis on chemical and physical transformations, monitoring, exposure, effects and scientific risk assessments. One innovative idea that actually worked was to establish an Office of Technical Information (OTI). Its function was to provide, at no cost to the inquirer, information on all aspects of the air pollution system, but primarily on these boxes with green labels in Figure 8.

The OTI unit of SAPRC became popular not only with other air pollution researchers, but also with the media, public school systems (3rd-12th grade) universities, legislators and other elected and appointed public servants.

The person responsible for setting it up was my Assistant Director, Alan Lloyd, a young researcher from the U.K. and U.S. Bureau of Standards. He did a great job then, and we didn't damage his long term career! Last year he retired as a member of Governor Schwarzenegger's Cabinet and continues to do well!

Our SAPRC research policy was to only accept public funds, with no strings attached. Furthermore, all interactions, for example, briefing legislators and their staff, were, if so desired, off the record...and kept that way!!! Similar ground rules applied to the media.

Among the public officials we briefed at SAPRC in the 1970s and early 1980s were then Governor Ronald Reagan (Figure 9) a Republican, and Jerry Brown, a Democrat and California's Secretary of State at the time (Figure 10). SAPRC was strictly non-partisan.

As a sidelight, in the early 1970s, while I had the funds needed to design and construct our evacuable smog chamber (Figure 11), I just couldn't dig up the \$25,000 needed to actually build the 25 kw solar simulator we had designed. It was to mimic a "true sun".

Well one day, in the early 1970s, when I was really "up a tree" with this critical

problem, my long term secretary, Mrs. Mae Minnich came in and said that the Secretary of State, Jerry Brown, was on the phone. I thought about all my sins, picked up the phone and heard "Hi Dr. Pitts. I'm Jerry Brown. I just successfully concluded a case against several oil companies (for election law violations) and have a check in my hands for a \$25,000 fine. Could you use it?"

**The Spectrum: And the rest is history...**

**Pitts:** The rest is history. The solar simulator is still working (see Figure 12) some 30 years later. Subsequently, he has

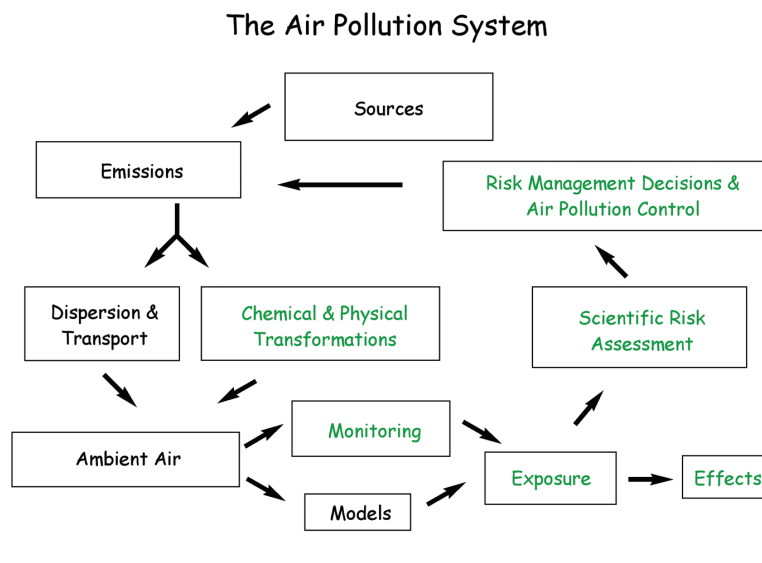

Figure 8. The air pollution system.

Courtesy of James N. Pitts, Jr.

been elected, and reelected, Governor of California (1974-1978), been Mayor of Oakland, and was recently elected state attorney general.



**Figure 9.** California Governor Ronald Reagan (right) at SAPRC briefing on air pollution circa 1972. Jim Pitts is conducting the briefing at the left.

Courtesy of James N. Pitts, Jr.



**Figure 10.** Jim Pitts (left) with Jerry Brown, current Attorney General of California, visiting SAPRC about 1971 as Secretary of State for California. His \$25,000 allotment funded the solar simulator for the environmental chamber.

Courtesy of James N. Pitts, Jr.

Both he and Governor Reagan have/had a great sense of humor. I was so fortunate to have interacted with such

gentlemen. Other distinguished elected officials we at SAPRC interacted with in the 1970s and 1980s included Jerry Lewis, who was a state Assemblyman and then a Congressman from our District. He is another great guy, smart, thoughtful, incisive, and with a real sense of humor. He's still our Congressman today.

#### ***The Spectrum:*** How did you obtain funding?

**Pitts:** The first key was having a supportive administration at UCR under the strong leadership of Chancellor Ivan Hinderaker. He made sure we had the base funding and administrative and infrastructure support for SAPRC so that we could do the outreach to the public and legislators, as well as maintain the research momentum.

The very bright members of our SAPRC team had some really imaginative ideas for exciting research projects. We all got together, picked out the most interesting, then I assigned one or two of the team with the most experience in those areas and "Tally Ho!" The research proposals were developed scientifically, then written and submitted to the appropriate public funding agencies. With a little bit of luck they were approved by the grantor.

The short answer is we had a team of very bright young men and women who had good research ideas and could write a strong proposal.

#### ***The Spectrum:*** How did you recruit that star-studded scientific team?

**Pitts:** Well we were dealing in all kinds of areas, kinetics, mechanisms, products, biological activities (formation and fates of airborne mutagens). Furthermore, the problems were interesting not only as fundamental research but they also addressed important, environmentally relevant topics. Finally, we already had a great team both scientifically and personally, and becoming a new member seemed like a good idea to many recruits.

I was also fortunate to have as collaborators a wonderful series of postdocs, graduate students and visitors over the years from all over the world. While I can't name them all, examples include Hajime Akimoto, who is one of the top atmospheric chemists in Japan; Uli Platt from Heidelberg, who is renowned for his spectroscopic measurements of trace gases in air; and Alf Bjørseth from Norway, who was elected to the Norwegian Academy of Sciences and named "Commander of the Royal Saint Olav Order" last year and is a leader in photodynamic therapies and solar photovoltaic development.



**The Spectrum:** What projects did you tackle at that point?

**Pitts:** Let me conclude by briefly citing some of our projects. First of all our research areas reflected our personal and professional philosophies, “The fundamental things apply, as time goes by”:

- Basic science is absolutely essential for answering key questions and developing sound control strategies.
- Ask the right questions, not only in research but also in its application to public policies.
- One never has complete information about complex environmental phenomena, but that should not prevent development and implementation of effective policies and controls.
- “Theories come and theories go, but good data stand forever.”, F. E. Blacet personal communication to J. G. Calvert and J. N. Pitts, Jr., 1946.

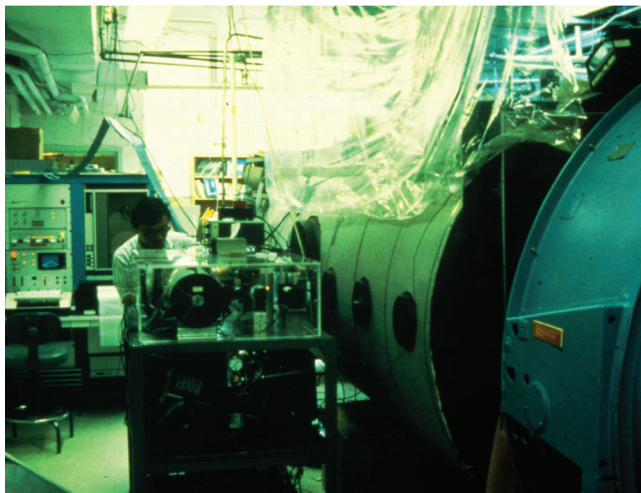
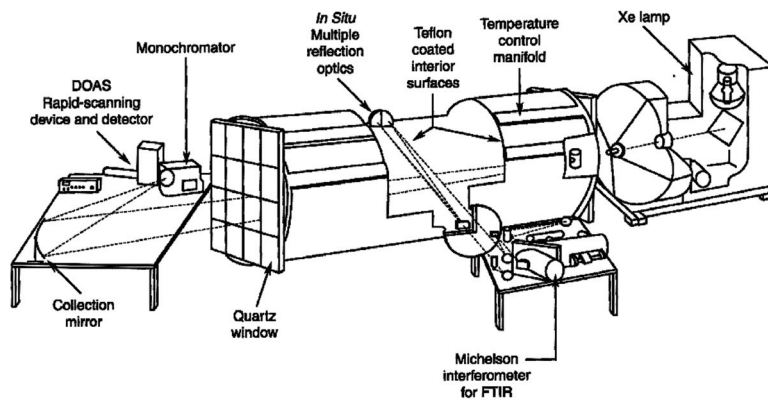

**Figure 12.** Photograph of the SAPRC environmental chamber with Dr. Ernie Tuazon, our spectroscopic “pro”.

Courtesy of James N. Pitts, Jr.

We note that when measuring pollutants in ambient air:

- Methods need to be specific and extremely sensitive.



**Figure 11.** Schematic diagram of the SAPRC environmental chamber.

Courtesy of James N. Pitts, Jr.

• Concentrations are in the parts per million (10<sup>-6</sup>) to parts per trillion (10<sup>-12</sup>) ranges.

Let me give you an example of how small these quantities are. Consider a dry martini:

1 ppb = add 1 drop of vermouth to 154 bathtubs of gin

1 ppt = add 1 drop of vermouth to 154,000 bathtubs of gin

Author’s note: This analogy is based on my suspicion that my Dad actually may have made “bathtub gin” during prohibition days of the late 1920s and early 1930s. (Barb would rather use the “drop per swimming pool” analogy.)

We conclude this section with some examples of SAPRC facilities and spectra. (Figures 11-15)

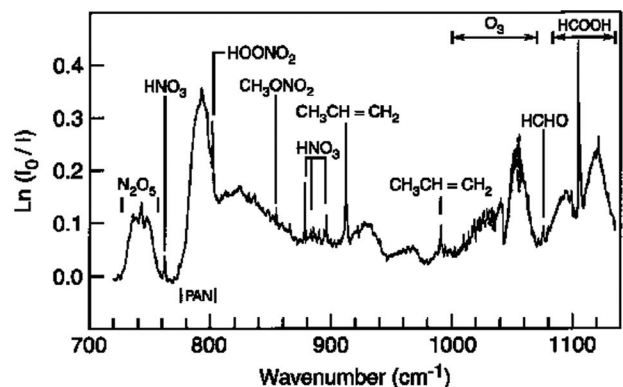

**Figure 13.** Typical infrared spectrum of irradiated VOC-NOx mixture in air.

Courtesy of James N. Pitts Jr.

**The Spectrum:** Are you concerned about any public misconceptions about air pollution?

**Pitts:** Yes. For example the widespread, but understandable, misconception that all so-called indoor air purifiers are safe and effective. I’m also deeply concerned about risk assessments of certain widely used pesticides. For example, some years ago as a member of California’s Scientific Review Panel for Toxic Air Contaminants, I (we) were called on to

evaluate a risk assessment for the over-the-counter pesticide malathion. The following is a direct quote from the evaluation, prepared by an important agency of our state, and submitted to our committee for review and evaluation:

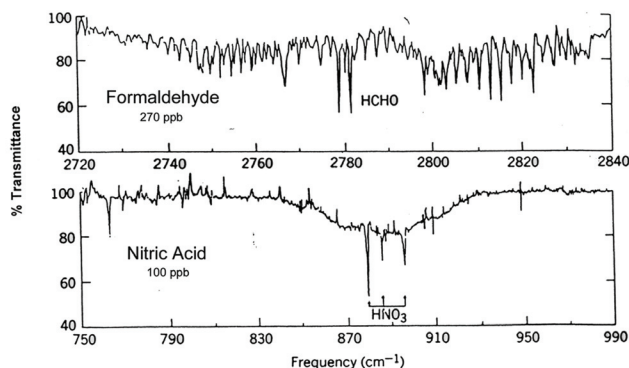

**Figure 14.** Long path FTIR spectra of two pollutants of major toxicological interest (Tuazon et al., 1978).

Courtesy of James N. Pitts, Jr.

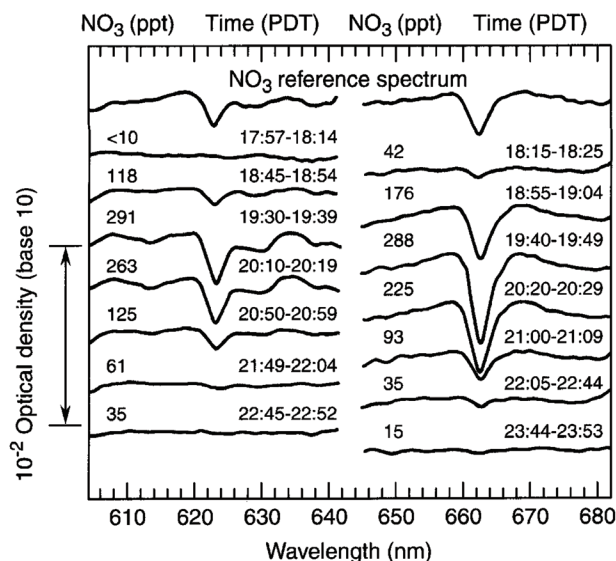
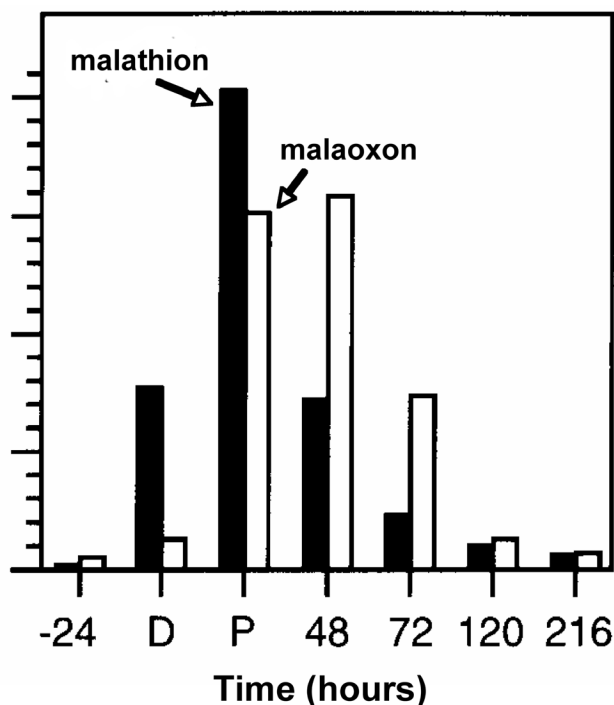

**Figure 15.** Observation of the NO<sub>3</sub> radical in ambient air by 1 km DOAS spectroscopy at UCR (U. Platt).

Courtesy of James N. Pitts, Jr.

“Because malaoxon constitutes less than 1% of the commercial malathion product and there is less of it in the environment, the hazard index levels for malaoxon are less than for malathion, although it is more toxic.”What the agency didn’t tell us (you) is that once malathion is sprayed into

urban/ suburban areas, it is rapidly oxidized to malaoxon (Figure 16), a highly toxic analog of the nerve agent SARIN (Figure 17).



**Figure 16.** Malathion and its oxidation products before and after spraying in residential areas in Southern California (from Brown et al. *ES&T* 1993, 27, 388).

Courtesy of James N. Pitts, Jr.

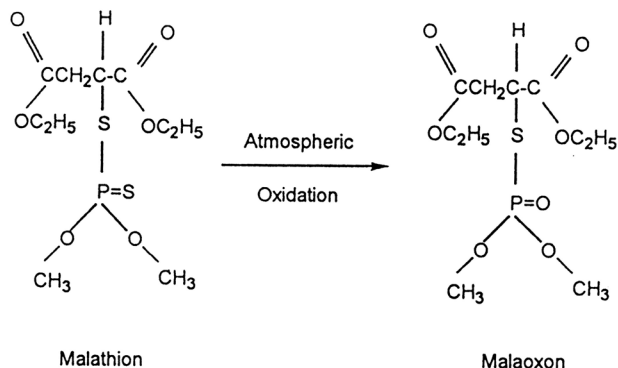

**Figure 17.** Oxidation of malathion to malaoxon.

Courtesy of James N. Pitts, Jr.



**The Spectrum:** When did you and Barbara first meet and what were your initial thoughts about her as a student? Do you have any advice for husband-wife teams collaborating on books, as you and Barbara did on *Chemistry of the Upper and Lower Atmosphere* (Academic Press, 2000) and *Atmospheric Chemistry: Fundamentals and Experimental Techniques* (Wiley, 1986), and on research? Tell us about your current book project.

**Pitts:** We met in my office at UCR in the fall of 1970, she having just arrived from Trent University in Canada. She had graduated with the highest honors and been offered the best scholarship in Canada to go to any Canadian University of her choice.

However, here's where Phil Leighton once again comes into the picture. Barb had written and asked his advice on research in the U.S and Leighton mentioned JNP as doing some interesting work. My initial thoughts of her as a student were very smart, enthusiastic, good sense of humor and hard worker.

Over the past 30 years of married life, and two coauthored books on atmospheric chemistry, they still are! Incidentally, she was first author on both books, and did most of the work. I'm so thankful for my "academic grandfather" (and her "academic great grandfather"), Phil Leighton's recommendation of yours truly as a Ph.D. research director!!!

Furthermore, over the decades she has done a great job of raising and training me and our "mutts" (a long line of golden retrievers). We're very proud of her. On Friday, April 27, 2007, we flew to Washington D.C. for the annual induction ceremony for new members of National Academy of Science to which Barb was elected last May.

Guys, it's really tough duty to be married to such a gal. And in further response to your question whenever we get into an argument of some kind, scientific or social, I generally lose...but no hard feelings. I answered one of your questions earlier regarding academic life in a department; it's the same approach at home. "Just salute and say Ma'am—and don't forget to give her the unexpected flowers, candy, and so forth. It works, and the rewards can be very positive!!!"

Let me conclude this interview with:

Special thanks go to my wife, Professor Barbara Finlayson-Pitts, senior author of our books and trainer of our golden and black Labrador retrievers...and me! She is the inspiration for my professional and personal lives!

Thanks to my colleagues in the department of chemistry and AirUCI for stimulating scientific interactions and the "bull sessions" on a great variety of topics!

Thanks also to:

Alisa Ezell (high school chemistry teacher) who stuck with me in putting together the material for this interview and doing the word processing on my handwritten scrawl.

Some of my former researchers—Professors Janet Arey and Roger Atkinson; Research Chemist Ernie Tuazon (UC Riverside); Professor Arthur Winer (UCLA); Dr. Alan Lloyd (UCR, CA ARB, CA EPA) and Professor Jeff Gaffney (UALR).

Finally, my deepest appreciation and affection to all of you brilliant, imaginative and hard-working junior and senior scientists, women and men, who came to work with us, early on in the Department of Chemistry and subsequently at SAPRC.

You are the ones truly responsible for the success of SAPRC, as well as a highly rewarding professional and personal life for "this old man".

Jim Pitts can be reached by telephone at 949.509.1766 or e-mail at [jnpitts@uci.edu](mailto:jnpitts@uci.edu).

### Brief Biography of James N. Pitts, Jr.

**JAMES N. PITTS, Jr.**, is a Research Chemist at the University of California, Irvine, and Professor Emeritus from the University of California, Riverside. He was Professor of Chemistry (1954-1988), co-founder (1961), and Director of the Statewide Air Pollution Research Center (1970-1988) at the University of California, Riverside. His research in atmospheric chemistry and air pollution has focused on the kinetics, mechanisms, and photochemistry of a variety of homogeneous and heterogeneous reactions, including those associated with the formation and fates, indoors and outdoors, of ozone and associated oxides of nitrogen, volatile organic compounds, and fine particles, as well as hazardous air pollutants, including ambient mutagens and carcinogens and certain widely used pesticides.

Dr. Pitts is the author or co-author of some 375 research publications and four books: *Chemistry of the Upper and Lower Atmosphere: Theory, Experiments and Applications* (Academic Press, 2000); *Atmospheric Chemistry: Fundamentals and Experimental Techniques* (Wiley, 1986); *Graduate School in the Sciences – Entrance, Survival, and Careers* (Wiley, 1972); and, *Photochemistry* (Wiley, 1966). He is included in Thomson's ISI Highly Cited Index of the top 250 most highly cited researchers in science in the world. He also has been co-founder and co-editor of two series: *Advances in Environmental Science and Technology*; and, *Advances in*

*Photochemistry*. He served as Chair of the State of California's Scientific Review Panel for Toxic Air Contaminants (1990-1997) and as a member of its Scientific Advisory Committee on Acid Deposition.

He was a research assistant in chemical warfare with the National Defense Research Committee from 1942 to 1945, and a research associate in an Army Special Projects program in biological warfare from 1945 to 1946. Following his Ph.D. at UCLA in 1949, he was on the faculty of Northwestern University (1949-1954), leaving to join the faculty at the new University of California, Riverside campus. He has an M.A. degree from Oxford (1965) where he was a Guggenheim Fellow at University College, Oxford (1961), and a Research Fellow of Merton College, Oxford (1965).

He is a member of Phi Beta Kappa and several professional societies, including Sigma Xi, the American Chemical Society, the American Physical Society, the American Geophysical Union, and is also a Fellow of the American Association for the Advancement of Science. Awards for his research include the "Service Through Chemistry Award" of the Orange County Section of the American Chemical Society (1973), the Clean Air Award of the California Lung Association (1979), the Frank A. Chambers Award for "Outstanding Achievement in the Science and Art of Air Pollution Control" from the Air Pollution Control Association (1982), the Richard C. Tolman Medal (1983), the UCR Faculty Research Lectureship (1965), the F. J. Zimmerman Award in Environmental Science (1984), the UCR Faculty Award for Public Service (1988) and the Carl Moyer Award from the Coalition for Clean Air for "scientific leadership and technical excellence" (2007).

On the occasion of his retirement from UCR in 1988, he received commendations from President Ronald Reagan, the State Senate Rules Committee (Senators Robert Presley and David A. Roberti), the State Assembly (Assemblyman Steve Clute), the California Air Resources Board, the Governing Board of the South Coast Air Management District (Chairman Norton Younglove), and Insertion in the Congressional Record (Congressman Jerry Lewis). He has also received a Lifetime Achievement Clean Air Award from the South Coast Air Management District (1992), a letter of commendation from Governor Pete Wilson in 1997 for his service on California's Scientific Review Panel for Toxic Air Contaminants, and the Haagen-Smit Award from the California Air Resources Board (2002) for "Outstanding

Contributions to Air Pollution Science". Recent invited lectures include: California Air Resources Board (2002), Pacific Northwest National Laboratories (2002), California District Attorneys Association (2002 and 2004), and the International Workshop on Indoor Chemistry and Health (2004).

